

VLT® Soft Start Controller MCD 100



MCD 100 is a cost effective and extremely compact soft starter for AC motors up to 11 kW. Due to a unique semiconductor design MCD 100 is a true “fit and forget” product. Selection can be made on the basis of the motor power – exactly as with traditional contactors.

The new range features three different products, MCD 100-001 (1,5 kW), MCD 100-007 (7,5 kW) and MCD 100-011 (11 kW). In fact the MCD 100-001 is **the world’s smallest soft starter** rated up to 1,5 kW. All sizes are rated for line voltages up to 600 V AC.

MCD 100 products provide timed voltage ramp up and down. Ramp time can be individually adjusted with rotary switches from 0,4 to 10 seconds. The start torque can be adjusted from 0 to 85% of the direct on-line torque.

Benefits with MCD 100 over traditional small soft starters

- A robust semiconductor design – selection can be based on motor power which ensures easy selection. Can be used for an almost unlimited number of starts per hour without derating.
- An universal control voltage (24-480 V AC/V DC) – simplifies selection and keeps stock at a minimum.
- A “fit and forget” contactor design – simplifies installation and reduces required panel space.
- Digitally controlled rotary switches – secures precise settings and simplifies installation.
- Ratings for heavy duty as standard – simplifies installation and reduce the risk of breakdown.

Application

MCD 100 is an ideal alternative when starting smaller AC motors direct on-line or with a star-delta starter. The typical applications would be soft start / stop of conveyor systems, pumps and soft start of smaller compressors for example scroll or reciprocating compressors in air-conditioning units.

MCD 100 products can be installed side by side and with or without a line contactor. Motor protection must be installed separately. Short circuit protection can be achieved by the use of fuses or a circuit breaker.

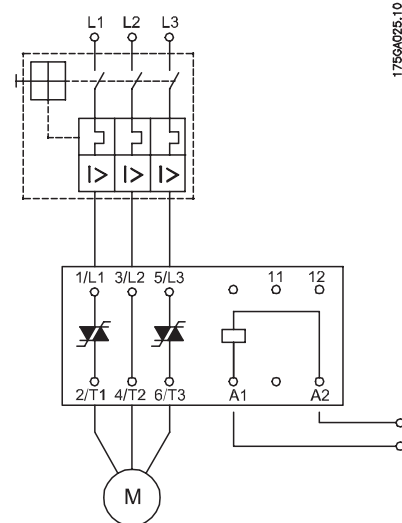

1756A025.10

Application example of a motor controlled by MCD100 and protected by a circuit breaker

Specification and ordering code numbers

Type	Max. power	Max. FLC	Voltage	Code number
MCD 100-001	0,7 kW	3 A	208 – 240 V	175G4000
MCD 100-001	1,5 Kw	3 A	400 – 415 V	175G4001
MCD 100-001	1,5 kW	3 A	440 – 480 V	175G4002
MCD 100-001	2,2 kW	3 A	550 – 600 V	175G4003
MCD 100-007	4 kW	15 A	208 – 240 V	175G4004
MCD 100-007	7,5 kW	15 A	400 – 480 V	175G4005
MCD 100-007	7,5 kW	15 A	500 – 600 V	175G4006
MCD 100-011	7,5 kW	25 A	208 – 240 V	175G4007
MCD 100-011	11 kW	25 A	400 – 480 V	175G4008
MCD 100-011	15 kW	25 A	500 – 600 V	175G4009

Technical data

	MCD 100-001	MCD 100-007	MCD 100-011
Dimensions (width)	22,5 mm	45 mm	90 mm
Load rating (EN 60947-4-2)	3A:5-5:10	15A:8-3:100-3000	25A:8-3:100-3000
Semiconductor protection			
Type 1	25 A gL/gG	50 A gL/gG	80 A gL/gG
Type 2	72 A ² s	1800 A ² s	6300 A ² s
Power loss	Max. 4 W	2 W/A x duty cycle	
Ambient temperature	-5 C to 40 C (above 40 C with derating)		
Approvals	CE, cULus		

For further technical data please download MCD 100 Design Guide (MG.12.A1.02) from www.Danfoss.com/drives or contact Danfoss.

A complete and innovative VLT® Soft Starter range from Danfoss Drives

The VLT® Soft Starter range features also the Compact Starter MCD 200 and the Digital Soft Starter MCD 3000

MCD 200 A compact soft starter for motors from 7,5 to 110 kW AC motors. MCD 200 has integral bypass relays to ensure minimum power losses, motor protection and current based soft start features. MCD 200 comes with a variety of accessories such as modules for serial communication (Profibus, DeviceNet, Modbus).

MCD 3000 A total motor starting solution for motors up to 800 kW. Configured inside the delta it can handle motors up to 1200 kW. MCD 3000 features numerous start, stop and protection features, it can be wall mounted or installed in motor control cabinets.

Danfoss can accept no responsibility for possible errors in catalogues, brochures and other printed material. Danfoss reserves the right to alter its products without notice. This also applies to products already on order provided that such alterations can be made without subsequential changes being necessary in specifications already agreed. All trademarks in this material are property of the respective companies. Danfoss and the Danfoss logotype are trademarks of Danfoss A/S. All rights reserved.