



VLT® Micro Drive

Small, powerful and built to last

Save panel space and reduce installation costs

150%

motor torque for up to 1 minute

enables you to use a smaller drive without sacrificing efficiency



Ready – Steady – Go!

Connect motor and power cables, turn the control knob, and watch the motor speed change



RoHS compliant

The VLT® Micro Drive does not contain lead, cadmium, hexavalent chrome, mercury, or flame retardant PBB and PBDE.

- 1** Well protected IP 20 enclosure
No forced air flow through electronics
- 2** IP 20 even without terminal cover
- 3** High quality capacitors
- 4** RFI Filter
- 5** DC-link access
- 6** Hot pluggable LCP
- 7** LCD display
- 8** Potentiometer
- 9** RS 485 pluggable
- 10** Customer relay screw terminals
Wire inlet from the bottom
- 11** Safety earth
– min. 4 mm² accessible from front
- 12** I/O terminals
- 13** Mains screw terminals
- 14** Motor screw terminals



Compact VLT® quality

VLT® Micro Drive is a genuine VLT® frequency converter with unsurpassed reliability, user-friendliness, condensed functionality, and is extremely easy to commission. Terminal numbers are named in the same manner as in the rest of the VLT® family.

Reliable and user friendly

The VLT® Micro Drive is a full member of the VLT® family, sharing the overall quality of design, reliability and user-friendliness.

Small drive – big performance

Despite the compact size and the easy commissioning, a VLT® Micro Drive can be set up to perform perfectly, even in complex application set-ups. Approximately 100 parameters can be set to optimize energy efficiency and operation.

| User friendly | |
|---------------------------------------|--------------------------------|
| Plug-and-play | Minimum effort – minimum time |
| Minimum commissioning | Save time |
| Copy settings via local control panel | Easy set up of multiple drives |
| Intuitive parameter structure | Minimal manual reading |
| Complies with VLT® software | Save commissioning time |

| Reliable | |
|---|----------------------|
| Optimum heat dissipation | Longer lifetime |
| High quality electronics/capacitors | Low lifetime cost |
| All drives full load tested from factory | High reliability |
| Earth fault, temperature and short circuit protection | Lean operation |
| Circuit boards well protected and coated | Increased robustness |

| Small drive – high performance | |
|---------------------------------------|-----------------------------------|
| Process PI-controller | No need for external controller |
| Automatic Energy Optimizer (AEO) | Less energy consumption |
| Automatic Motor Tuning (AMT) | Exploit motor's full potential |
| 150% motor torque up to 1 minute | Replace need for bigger drive |
| Flying start (catch a spinning motor) | Lean operation – more up-time |
| Electronic Thermal relay (ETR) | Replace external motor protection |
| Smart Logic Controller | Often makes PLC ommissible |
| Built-in RFI filter | Save cost and space |

In- and outputs

- 5 programmable digital inputs
- PNP/NPN selection
- Pulse input 20 – 5000 Hz
- 1 analogue input
0 – 10 V or 0 – 20 mA
- 1 analogue input 0 – 20 mA
- Thermistor input
(analogue/digital)
- 1 analogue output 0 – 20 mA
- 1 relay 240 V AC, 2 A
- RS485 FC-bus
- Modbus RTU

Compact general purpose drive

The VLT® Micro Drive is a general purpose drive that can control AC motors up to 22 kW.



Compact design – Uncompromised quality

Space saving

A compact, book-style design allows side-by-side mounting without derating.

Minimum penetration of dust

VLT® Micro Drives are designed to keep the forced ventilation away from the electronics. Printed circuit boards are well protected inside the drive.

Built-in RFI

Radio disturbance from motor cables is limited with the built-in RFI filter, which allows for 15 m motor cables (screened). Meets EU norms.

Built-in brake functions

With built in DC and AC brake functions, VLT® Micro Drive can transform kinetic energy in the

application into braking power to slow down the motor. A brake chopper is built in the drives from 1.5 kW upwards.

Intelligent heat management

Process heat is removed through the heat sink, leaving electronics protected from dust and dirt from production.

Coated electronics are standard

All VLT® Micro Drives use coated electronics for longer lifetime and reliability.

Effective heat sink

An effective heat sink removes heat from the electronics and extends the lifetime and reliability of the drive.

Energy efficiency 98%

High quality VLT® power modules ensure cool running of the drive due to low losses.

50° ambient temperature

Highly efficient cooling allows up to 50° ambient temperature.



Hot pluggable display – with or without potentiometer

- LCP without potentiometer IP 54
- LCP with potentiometer IP 21
- Remote mounting kit
- LCP copy function
- Parameter numbers and values visible simultaneously
- Unit indications (A., V, Hz, RPM, %, s, HP and kW)
- Rotation direction indication
- Setup indication – 2 setups
- Removable during operation
- Up- and download functionality

Large figures, easy to read

- Display readable from distance
- Operation buttons are illuminated when active

Quick Menus

- A Danfoss defined Quick Menu
- Basic settings
- PI controller

Menu structure

- Based on the well-known matrix from the VLT® family
- Easy shortcut for the experienced user
- Edit and operate in different set-ups simultaneously

Remote mountable

Illuminated LCD display

Navigation buttons

Indicators
Operation buttons



Two control panel versions.
Potentiometer is optional.

The control panels are shown in actual size.
H x W x D = 85 x 65 x 20 mm
(D = 28 mm with potentiometer)

Built-in Smart Logic Controller

The smart logic controller is a simple, yet clever, way to make your drive, motor and application work seamlessly together.

The smart logic controller is able to monitor any parameter that can be characterized as “true” or “false”.

This includes digital commands and also logic expressions, which allow even sensor outputs to influence the operation.

Temperature, pressure, flow, time, load, frequency, voltage and other

parameters combined with the operators “>”, “<”, “=”, “and” and “or” form logic expressions that are true or false. That is why Danfoss calls it a “logic”

controller. As a result of this, you can program the controller to react to literally any event.

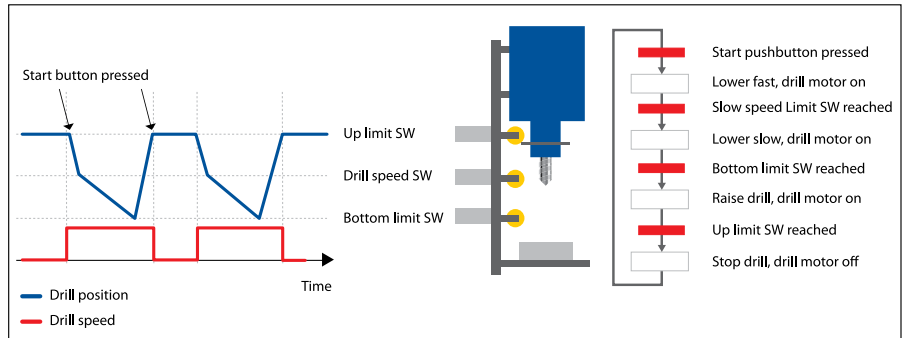

Option - VLT® Line Filter MCC 107

Improve both the low and high frequency performance of the line current to the drive with the optional VLT® Micro Drive Line Filter, which boosts efficiency by combining a harmonic filter and an EMC filter.

Increased drive lifetime

Reducing the voltage ripple on the DC link will result in higher reliability and longer drive lifetime. Under similar running conditions (temperature, load), the expected lifetime of the DC capacitors may be extended by 2-3 times.

Improved power-factor

The VLT® Line Filter reduces the RMS value of line current. A smaller line current means higher true power-factor (PF). Typically, line current can be reduced by more than 40% and improve PF from 0.4 to 0.7 for single-phase drives and 0.47 to 0.9 for three-phase drives.

Improved high frequency conduction EMC performance

The VLT® Line Filter ensures compliance with EN55011 class A1 for up to 50m of motor cable, and class B up to 10m of motor cable.

That means the VLT® Micro Drive + VLT® Line Filter, has an outstanding EMC performance in the micro- inverter class, even with relatively long motor cables.

High immunity against grid disturbances

The line filter will reduce the harmonic current drawn from the grid. The drive will comply with IEC61000-2-2 and IEC6100-2-4 without power derating, including 15% harmonic voltage distortion, 3% voltage imbalance and commutation notches, as described in IEC60146-1. With the line filter, the performance of the immunity to the surge and burst impact of the drive stated in IEC61800-3 will be greatly improved.

One filter for several drives

The line filter can be used for filtering several small VLT® Micro Drives. In this case the line filter should be derated by one size. Example: 1x FC 51 400V/1,5 kW + 1x FC 51 400V/1,5 kW -> total 3,0 kW + derating one size up: select filter 400V/4,0 kW.



Frame sizes
Three different frame sizes of line filters correspond to the M1, M2 and M3 enclosures of the VLT® Micro Drive

Connections

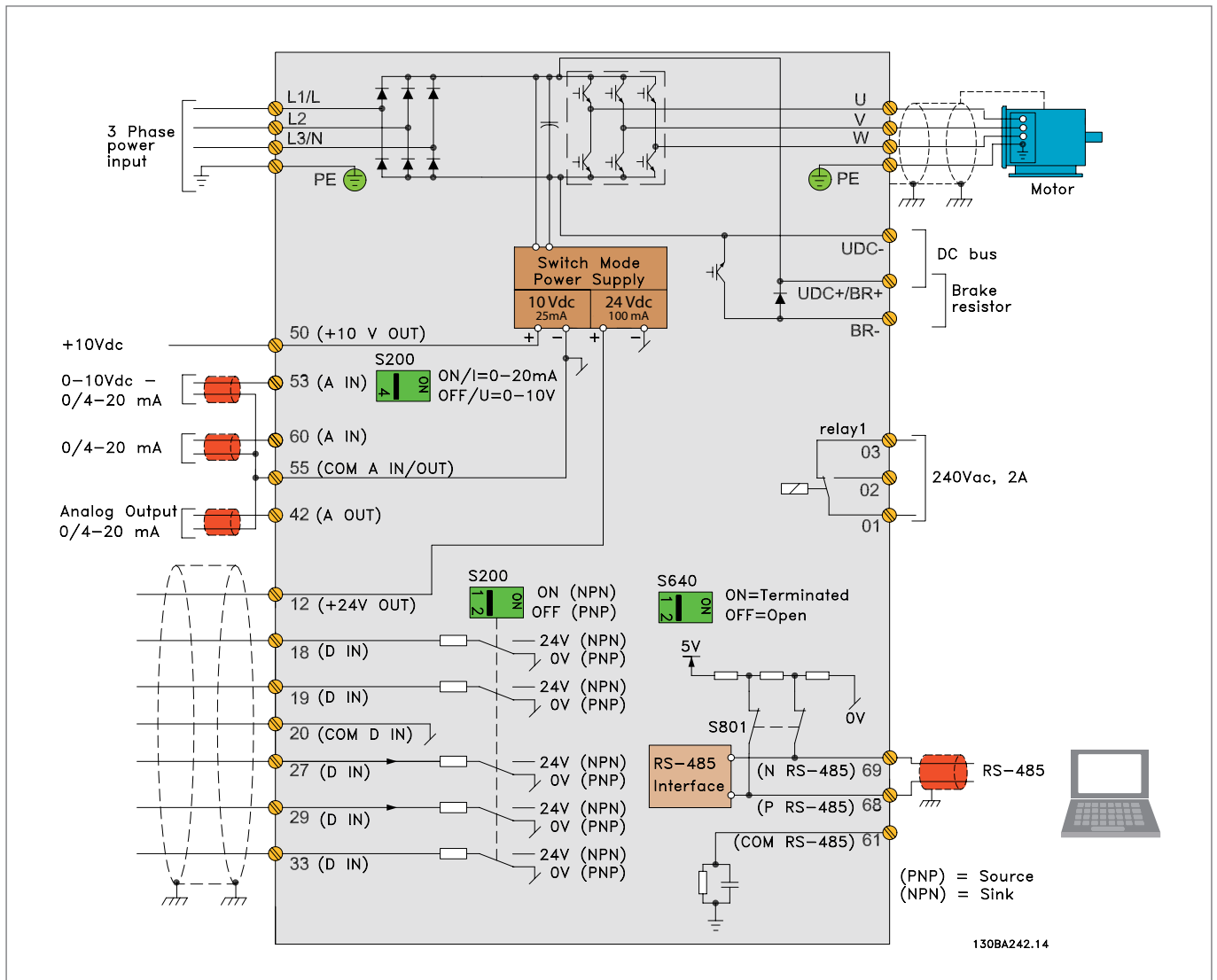

Accessories



Set-up software

The VLT® Motion Control Tool MCT 10 Setup Software exploits the full functionality of your PC, providing a general overview and control of even large systems.



Remote mounting kit

A dedicated mounting kit is available for mounting the local control panel (LCP) in the cabinet door.

Code numbers

VLT® Control panel LCP 11
W/o potentiometer 132B0100

VLT® Control panel LCP 12
With potentiometer 132B0101

Remote mounting kit
incl. 3 m cable 132B0102

Decoupling plate

For EMC optimized installation.

*Dedicated external filters
are available on request.*

Specifications

| Mains supply (L1, L2, L3) | |
|--|--|
| Supply voltage | 1 x 200–240 V ± 10%, 3 x 200–240 V ± 10% 3 x 380–480 V ± 10% |
| Supply frequency | 50/60 Hz |
| Displacement Power Factor (cos φ) near unity | (> 0.98) |
| Switching on input supply L1, L2, L3 | 1–2 times/min. |

| Output data (U, V, W) | |
|-----------------------|---|
| Output voltage | 0–100% of supply voltage |
| Output frequency | 0–200 Hz (VVC+ mode) 0–400 Hz (U/f mode) |
| Switching on output | Unlimited |
| Ramp times | 0.05–3600 sec |

| Digital inputs | |
|--------------------------|--------------|
| Programmable inputs | 5 |
| Logic | PNP or NPN |
| Voltage level | 0–24 V |
| Maximum voltage on input | 28 V DC |
| Input Resistance, Ri | Approx. 4 kΩ |

| Pulse inputs | |
|------------------------------------|--------------------------------|
| Programmable pulse inputs | 1 |
| Voltage level | 0–24 V DC (PNP positive logic) |
| Pulse input accuracy (0,1–110 kHz) | Max. error: 0.1% of full scale |
| Pulse input frequency | 20–5000 Hz |

| Analog input | |
|---------------|--------------------------------|
| Analog inputs | 2 |
| Modes | 1 current/1 voltage or current |
| Voltage level | 0–10 V (scaleable) |
| Current level | 0/4–20 mA (scaleable) |

| Analog output | |
|--------------------------------------|------------------------------|
| Programmable analog outputs | 1 |
| Current range at analog output | 0/4–20 mA |
| Max. load to common at analog output | 500 Ω |
| Accuracy on analog output | Max. error: 1% of full scale |

Ordering Numbers

| Power [kW] | 200–240 V | | | 380–480 V | |
|------------|------------------|-----------|-----------|------------------|-----------|
| | Current [I-nom.] | 1 ph. | 3 ph. | Current [I-nom.] | 3 ph. |
| 0.18 | 1.2 | 132F 0001 | | | |
| 0.25 | 1.5 | | 132F 0008 | | |
| 0.37 | 2.2 | 132F 0002 | 132F 0009 | 1.2 | 132F 0017 |
| 0.75 | 4.2 | 132F 0003 | 132F 0010 | 2.2 | 132F 0018 |
| 1.5 | 6.8 | 132F 0005 | 132F 0012 | 3.7 | 132F 0020 |
| 2.2 | 9.6 | 132F 0007 | 132F 0014 | 5.3 | 132F 0022 |
| 3.0 | | | | 7.2 | 132F 0024 |
| 3.7 | 15.2 | | 132F 0016 | | |
| 4.0 | | | | 9.0 | 132F 0026 |
| 5.5 | | | | 12.0 | 132F 0028 |
| 7.5 | | | | 15.5 | 132F 0030 |
| 11.0 | | | | 23.0 | 132F 0058 |
| 15.0 | | | | 31.0 | 132F 0059 |
| 18.5 | | | | 37.0 | 132F 0060 |
| 22.0 | | | | 43.0 | 132F 0061 |

Micro drives from 1.5 kW and up have built in brake chopper

| On-board power supply | |
|-----------------------|--------------------------|
| Output voltage | 10.5 ± 0.5 V, 24 ± 0.5 V |
| Max. load (10 V) | 25 mA |
| Max. load (24 V) | 100 mA |

| Relay outputs | |
|----------------------------|---------------|
| Programmable relay outputs | 1 |
| Max. terminal load | 240 V AC, 2 A |

| Fieldbus communication | |
|-------------------------|--|
| FC Protocol, Modbus RTU | |

| Cable lengths | |
|--|------|
| Max. motor cable length, screened (shielded) | 15 m |
| Max. motor cable length, unscreened (unshielded) | 50 m |

| Surroundings/ External | |
|------------------------|---|
| Enclosure | IP 20 |
| Vibration test | 0.7 g |
| Max. relative humidity | 5%–95% (IEC 721-3-3; Class 3K3 (non-condensing) during operation) |
| Aggressive environment | (IEC 721-3-3), coated class 3C3 |
| Ambient temperature | Max. 50° C |
| 24-hour average | Max. 40° C |

| Approvals | |
|----------------|--|
| CE, C-tick, UL | |

| Protection and features | |
|--|--|
| <ul style="list-style-type: none"> • Electronic thermal motor protection against overload • Temperature monitoring of the heat sink protects the drive from overheating • The drive is protected against short-circuits on motor terminals U, V, W • The drive is protected against earth fault on motor terminals U, V, W | |



Cabinet sizes (mounting flange incl.)

| [mm] | M1 | M2 | M3 | M4 | M5 |
|--------|-----|-----|-----|-----|-----|
| Height | 150 | 176 | 239 | 292 | 335 |
| Width | 70 | 75 | 90 | 125 | 165 |
| Depth | 148 | 168 | 194 | 241 | 248 |

+ 6 mm with potentiometer



What VLT® is all about

Danfoss VLT Drives is the world leader among dedicated drives providers – and still gaining market share.

Environmentally responsible

VLT® products are manufactured with respect for the safety and well-being of people and the environment.

All activities are planned and performed taking into account the individual employee, the work environment and the external environment. Production takes place with a minimum of noise, smoke or other pollution and environmentally safe disposal of the products is pre-prepared.

UN Global Compact

Danfoss has signed the UN Global Compact on social and environmental responsibility and our companies act responsibly towards local societies.

EU Directives

All factories are certified according to ISO 14001 standard. All products fulfil the EU Directives for General Product Safety and the Machinery directive. Danfoss VLT Drives is, in all product series, implementing the EU Directive concerning Hazardous Substances in Electrical and Electronic Equipment (RoHS) and is designing all new product series according to the EU Directive on Waste Electrical and Electronic Equipment (WEEE).

Impact on energy savings

One year's energy savings from our annual production of VLT® drives will save the energy equivalent to the energy production from a major power plant. Better process control at the same time improves product quality and reduces waste and wear on equipment.

Dedicated to drives

Dedication has been a key word since 1968, when Danfoss introduced the world's first mass produced variable speed drive for AC motors – and named it VLT®.

Twenty five hundred employees develop, manufacture, sell and service drives and soft starters in more than one hundred countries, focused only on drives and soft starters.

Intelligent and innovative

Developers at Danfoss VLT Drives have fully adopted modular principles in development as well as design, production and configuration.

Tomorrow's features are developed in parallel using dedicated technology platforms. This allows the development of all elements to take place in parallel, at the same time reducing time to market and ensuring that customers always enjoy the benefits of the latest features.

Rely on the experts

We take responsibility for every element of our products. The fact that we develop and produce our own features, hardware, software, power modules, printed circuit boards, and accessories is your guarantee of reliable products.

Local backup – globally

VLT® motor controllers are operating in applications all over the world and Danfoss VLT Drives' experts located in more than 100 countries are ready to support our customers with application advice and service wherever they may be.

Danfoss VLT Drives experts don't stop until the customer's drive challenges are solved.

